

For 125 years, Weil McLain has shaped an industry and exceeded the expectations of both homeowners and heating contractors - and the legacy continues. Introducing Weil-McLain's Next Generation of Oil Boiler ...the Ultra Oil

# Welcome to the Family

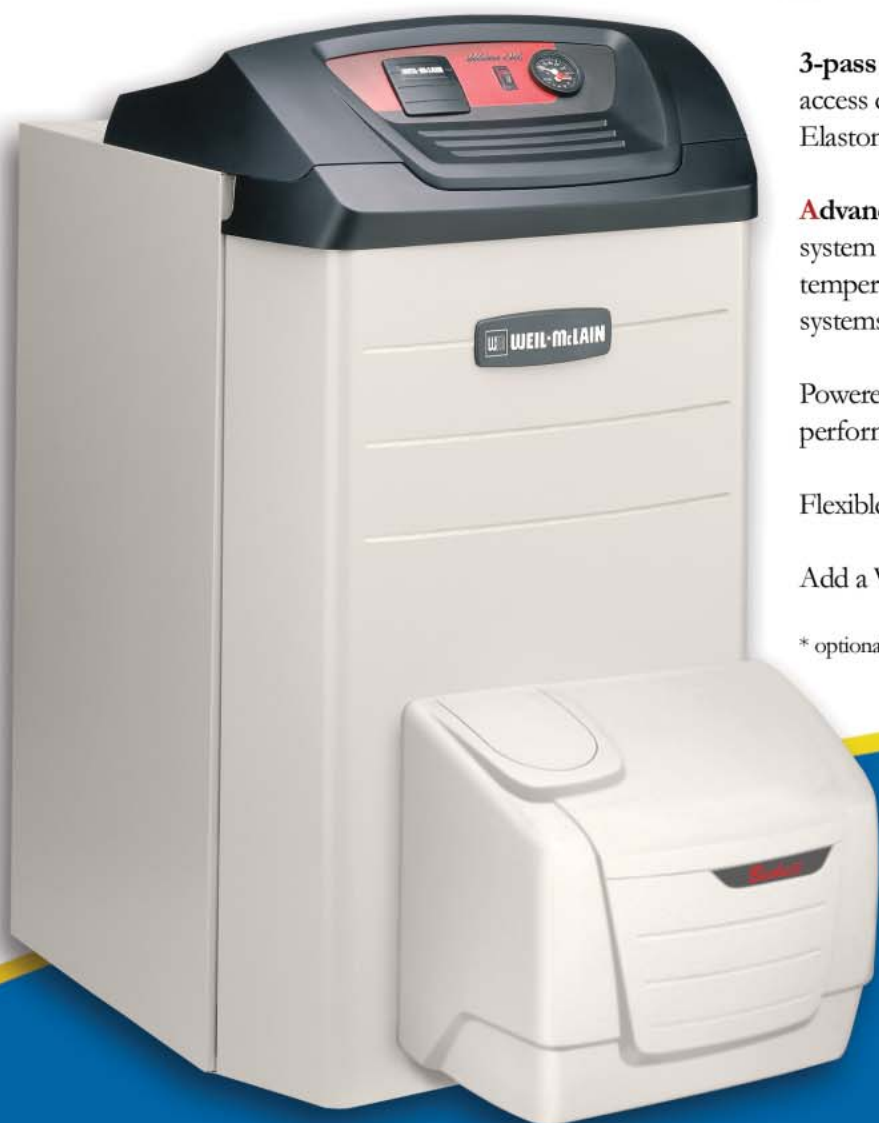

**3-pass cast iron heat exchanger** with reversible, full-size swing out access door for easy cleaning and service. Sealed by Weil-McLain's Elastomer seals. 35 Years and going strong.

**Advanced Feature Module (AFM)\*** a low cost innovative control system that provides indoor/outdoor reset, low temperature mixing, DHW priority, stage firing for multiple boiler systems, and much more.

Powered exclusively by Beckett NX Oil Burner for high performing, clean & quiet operation.

Flexible direct or chimney venting.

Add a Weil-McLain Plus Water Heater for abundant hot water.

\* optional equipment

 **WEIL-McLAIN**

*UltraOil*

American ingenuity. ULTRA results.

Available  
Fall 2005

**Earning The Trust of Generations.**

Visit [weil-mclain.com](http://weil-mclain.com) to see the entire family of Weil-McLain products.  
Weil-McLain • 500 Blaine Street • Michigan City, IN 46360 • 219-879-6561



# UltraOil

American ingenuity. ULTRA results.



## Features:

Weil-McLain designed and manufactured 3-pass cast iron high efficiency heat exchanger.

Powered by Beckett NX burner with Exclusive Weil-McLain designed burner cover for clean, quiet operation.

Optional **AFM** Advanced **F**eatures **M**odule available – Provides indoor/outdoor reset, multi-temp control, DHW priority and more...

Sleek, innovative jacket design with integrated hinged pod for easy access to control tray. Pod fully conceals factory-supplied components and wiring.

Factory tested and assembled cast iron boiler sections with limited lifetime warranty.

Reversible swing away burner door providing full access to flue-ways.

Captured seal design, a Weil-McLain exclusive for 35 years.

Chimney vent or direct vent with no external draft inducer needed

## Includes:

EnviraCOM™ ready Honeywell L7248 electronic oil aquastat for diagnostic information at your finger tips

Factory-wired terminal strip eliminates wiring guesswork, reduces additional material costs, installation time and easily accepts additional controls for high limit and low water cut-offs

Standard equipment includes service switch, temperature/pressure gauge, boiler drain, barometric damper and 30 psi relief valve (boiler tested for 50 psi max working pressure)

Available 5 or 10 year Home Owner Protection Plan

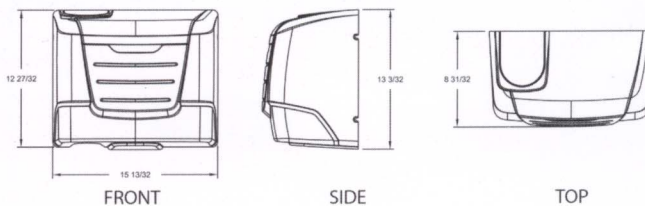
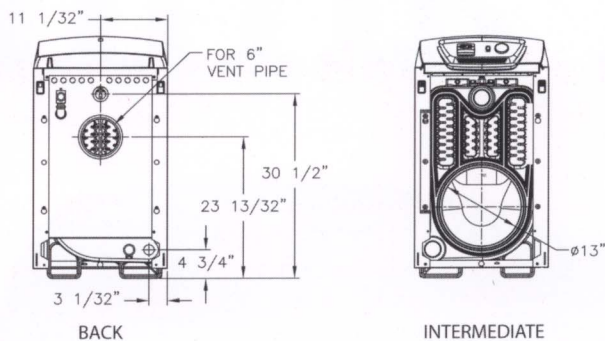
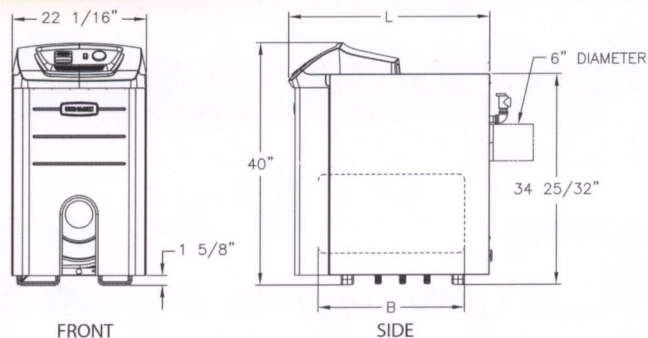

## Specifications

Model #	I=B=R Burner Capacity gph	CSA Input MBH	DOE* Heating Capacity MBH	Net* I=B=R Ratings MBH	DOE* Seasonal Efficiency AFUE %	Draft Loss Through Boiler (inches wc)
UO-3	0.80	112	98	85	86.5	.000
UO-3	1.00	140	122	106	86.5	.020
UO-4	1.20	168	146	127	86.2	.025
UO-5	1.40	196	172	150	86.5	.040

\* Pending Certification

## Dimensions

Model #	Supply Tapping	Return Tapping	B	L	Approx Shipping Wgt
UO-3	1 1/2"	1 1/2"	16	25	636
UO-3	1 1/2"	1 1/2"	16	25	636
UO-4	1 1/2"	1 1/2"	20	29	737
UO-5	1 1/2"	1 1/2"	24	33	852



Weil-McLain • 500 Blaine Street  
Michigan City, IN 46360 • 219-879-6561